

Solid State Relays System Monitoring Relays (Sense Relay) Type RA.... ..S



- System (line and load) monitoring relay
- Zero switching
- Rated operational current: 25, 50, 90 and 110 AACrms
- Rated operational voltage: 120, 230, 400 and 480 VACrms
- High surge current capability
- Alarm output signal
- LED indication for alarm and supply



Product Description

The system monitoring solid state relay (sense relay) provides an alarm output in the event of a circuit failure. Internal circuits monitor:

- line voltage/line current
- correct functioning of the SSR
- SSR input status

The relay is designed for applications where immediate fault detection is required. A red LED indicates an alarm, a green LED indicates DC control supply OK (half LED light intensity) resp. relay switched ON (full LED light intensity).

Ordering Key

RA 23 25 H 06 NO S

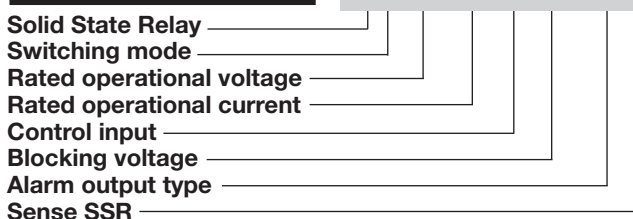

Type Selection

Switching mode	Rated operational voltage	Rated operational current input	Control voltage	Blocking voltage	Alarm output
A: Zero switching	12: 120 VACrms 23: 230 VACrms 40: 400 VACrms 48: 480 VACrms	25: 25 AACrms 50: 50 AACrms 90: 90 AACrms 110: 110 AACrms	H: Active high	06: 650 V _p 10: 1000 V _p 12: 1200 V _p	NO: NPN, NO NC: NPN, NC PO: PNP, NO PC: PNP, NC

Selection Guide

Rated op. voltage	Control input type	Alarm output	Rated operational current			
			25 AACrms	50 AACrms	90 AACrms	110 AACrms
120 VACrms	Active high	NPN, NO	RA 1225 H06NOS	RA 1250 H06NOS	RA 1290 H06NOS	RA 12110 H06NOS
		NPN, NC	RA 1225 H06NCS	RA 1250 H06NCS	RA 1290 H06NCS	RA 12110 H06NCS
		PNP, NO	RA 1225 H06POS	RA 1250 H06POS	RA 1290 H06POS	RA 12110 H06POS
		PNP, NC	RA 1225 H06PCS	RA 1250 H06PCS	RA 1290 H06PCS	RA 12110 H06PCS
230 VACrms	Active high	NPN, NO	RA 2325 H06NOS	RA 2350 H06NOS	RA 2390 H06NOS	RA 23110 H06NOS
		NPN, NC	RA 2325 H06NCS	RA 2350 H06NCS	RA 2390 H06NCS	RA 23110 H06NCS
		PNP, NO	RA 2325 H06POS	RA 2350 H06POS	RA 2390 H06POS	RA 23110 H06POS
		PNP, NC	RA 2325 H06PCS	RA 2350 H06PCS	RA 2390 H06PCS	RA 23110 H06PCS
400 VACrms	Active high	NPN, NO	RA 4025 H10NOS	RA 4050 H10NOS	RA 4090 H10NOS	RA 40110 H10NOS
		NPN, NC	RA 4025 H10NCS	RA 4050 H10NCS	RA 4090 H10NCS	RA 40110 H10NCS
		PNP, NO	RA 4025 H10POS	RA 4050 H10POS	RA 4090 H10POS	RA 40110 H10POS
		PNP, NC	RA 4025 H10PCS	RA 4050 H10PCS	RA 4090 H10PCS	RA 40110 H10PCS
480 VACrms	Active high	NPN, NO	RA 4825 H12NOS	RA 4850 H12NOS	RA 4890 H12NOS	RA 48110 H12NOS
		NPN, NC	RA 4825 H12NCS	RA 4850 H12NCS	RA 4890 H12NCS	RA 48110 H12NCS
		PNP, NO	RA 4825 H12POS	RA 4850 H12POS	RA 4890 H12POS	RA 48110 H12POS
		PNP, NC	RA 4825 H12PCS	RA 4850 H12PCS	RA 4890 H12PCS	RA 48110 H12PCS

General Specifications

	RA12...06..S	RA23...06..S	RA40...10..S	RA48...12..S
Operational voltage range	60 to 140 VACrms	170 to 250 VACrms	150 to 440 VACrms	180 to 530 VAC
Blocking voltage	650 V _p	650 V _p	1000 V _p	1200 V _p
Zero voltage turn-on	≤ 15 V	≤ 15 V	≤ 15 V	≤ 25 V
Operational frequency range	45 to 65 Hz	45 to 65 Hz	45 to 65 Hz	45 to 65 Hz
Power factor cos φ	≥ 0.5 @ 120 VACrms	≥ 0.5 @ 230 VACrms	≥ 0.5 @ 400 VACrms	≥ 0.5 @ 480 VACrms
CE marking	Yes	Yes	Yes	Yes
Compliance	UR, CSA, EAC	UR, CSA, EAC	UR, CSA, EAC	UR, CSA, EAC

Control Specifications

Supply voltage range	20 to 32 VDC	PNP Alarm output Alarm output voltage open Alarm output voltage @ 100 mA Alarm output current	0 VDC V _{cc} - 2 VDC ≤ 100 mA
Supply current @ 24 VDC	≤ 40 mADC		
Response time pick-up @ 50 Hz	≤ 10 ms		
Response time drop-out @ 50 Hz	≤ 10 ms		
Active high control input		PNP Alarm output Alarm output voltage open Alarm output voltage @ 100 mA Alarm output current	≤ 32 VDC 2 VDC ≤ 100 mA
Pick-up voltage	Typ. 7 VDC		
Drop-out voltage	Typ. 6.8 VDC		
Input current (V _c = 32 V)	≤ 4 mA		

Output Specifications

	RA..25.06..S	RA..50.06..S	RA..90.10..S	RA..110.12..S
Rated operational current AC 51	≤ 25 Arms	≤ 50 Arms	≤ 90 Arms	≤ 110 Arms
AC 53a	5 Arms	15 Arms	20 Arms	30 Arms
Min. operational load current	≤ 200 mA	≤ 250 mA	≤ 400 mA	≤ 500 mA
Non-rep. surge current t=10 ms	≤ 325 A _p	≤ 600 A _p	≤ 1150 A _p	≤ 1900 A _p
Off-state leakage current @ rated voltage and frequency	≤ 6 mA	≤ 6 mA	≤ 6 mA	≤ 6 mA
I ² t for fusing t=10 ms	≤ 525 A ² s	≤ 1800 A ² s	≤ 6600 A ² s	≤ 18000 A ² s
Critical dv/dt	≥ 500 V/μs	≥ 500 V/μs	≥ 500 V/μs	≥ 500 V/μs

Sense Specifications

	RA12..06..S	RA23..06..S	RA40..10..S	RA48..12..S
Current				
Sensed load current	≥ 50 mA	≥ 50 mA	≥ 50 mA	≥ 50 mA
Non-sensed leakage current	≤ 20 mA	≤ 20 mA	≤ 20 mA	≤ 20 mA
Voltage				
Sensed line voltage	≥ 60 Vrms	≥ 120 Vrms	≥ 150 Vrms	≥ 180 Vrms
Non-sensed line voltage	≤ 30 Vrms	≤ 50 Vrms	≤ 80 Vrms	≤ 100 Vrms
Timing				
Response time from fault to alarm output	≤ 100 ms	≤ 100 ms	≤ 100 ms	≤ 100 ms
Short-circuit of semiconductor	Will be sensed	Will be sensed	Will be sensed	Will be sensed

Thermal Specifications

	RA..25.....S	RA..50.....S	RA..90.....S	RA..110.....S
Operating temperature	-20°C to +70°C (-4°F to +158°F)	-20°C to +70°C (-4°F to +158°F)	-20°C to +70°C (-4°F to +158°F)	-20°C to +70°C (-4°F to +158°F)
Storage temperature	-40°C to +100°C (-40°F to +212°C)	-40°C to +100°C (-40°F to +212°C)	-40°C to +100°C (-40°F to +212°C)	-40°C to +100°C (-40°F to +212°C)
Junction temperature	≤ 125°C (257°F)	≤ 125°C (257°F)	≤ 125°C (257°F)	≤ 125°C (257°F)
R _{th} junction to case	≤ 1.25 °C/W	≤ 0.65 °C/W	≤ 0.35 °C/W	≤ 0.30 °C/W
R _{th} junction to ambient	≤ 12 °C/W	≤ 12 °C/W	≤ 12 °C/W	≤ 12 °C/W

Environmental Specifications

Pollution degree	2 (non-conductive pollution with possibilities of condensation)
EU RoHS compliant	Yes
China RoHS compliant	Refer to Environmental Information (Page 6)

Isolation

Rated isolation voltage Input to output	≥ 4000 VACrms
Rated isolation voltage Output to case	≥ 4000 VACrms

Functional Diagram

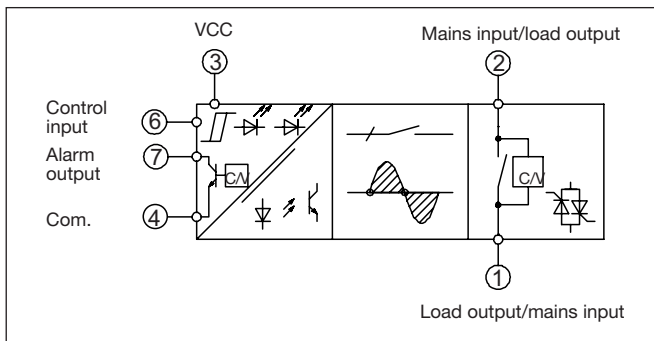

Wiring Diagrams

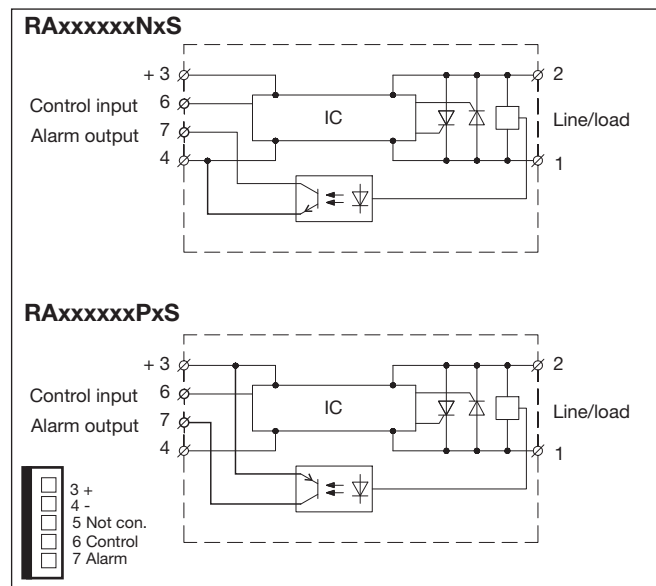

Operation Diagram

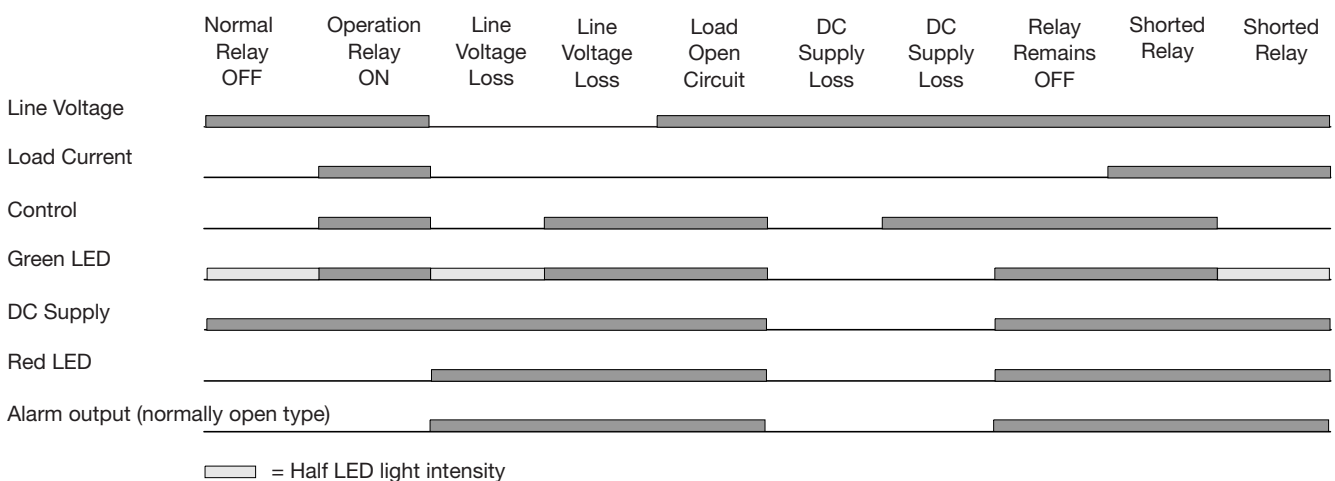



Heatsink Dimensions (load current versus ambient temperature)

RA ..25S

Load current [A]	Thermal resistance [°C/W]						Power dissipation [W]
	20	30	40	50	60	70	
25	2	1.7	1.4	1	0.71	0.40	32
22.5	2.5	2.1	1.8	1.4	1	0.66	27
20	3.1	2.7	2.3	1.9	1.4	1	23
17.5	4	3.5	3	2.5	2	1.4	20
15	4.9	4.3	3.7	3.1	2.5	1.9	16
12.5	6.2	5.4	4.6	3.9	3.1	2.3	13
10	8.1	7.1	6.1	5.1	4	3	10
7.5	11.3	9.9	8.5	7.1	5.6	4.2	7
5	-	15.6	13.3	11.1	8.9	6.7	5
2.5	-	-	-	-	18.7	14	2

T_A
Ambient temp. [°C]

RA ..50S

Load current [A]	Thermal resistance [°C/W]						Power dissipation [W]
	20	30	40	50	60	70	
50	0.92	0.76	0.60	0.45	0.29	-	63
45	1.2	0.99	0.80	0.62	0.44	0.26	55
40	1.5	1.3	1.1	0.85	0.63	0.42	47
35	1.9	1.6	1.4	1.1	0.89	0.63	40
30	2.4	2.1	1.8	1.5	1.2	0.91	33
25	3	2.7	2.3	1.9	1.5	1.1	26
20	3.9	3.5	3	2.5	2	1.5	20
15	5.5	4.8	4.1	3.4	2.7	2.1	15
10	8.6	7.5	6.4	5.4	4.3	3.2	9
5	17.9	15.6	13.4	11.2	8.9	6.7	4

T_A
Ambient temp. [°C]

RA ..90S

Load current [A]	Thermal resistance [°C/W]						Power dissipation [W]
	20	30	40	50	60	70	
90	0.63	0.53	0.42	0.32	-	-	97
80	0.81	0.69	0.57	0.45	0.33	-	84
70	1	0.89	0.75	0.61	0.47	0.33	71
60	1.3	1.2	1	0.83	0.66	0.49	59
50	1.7	1.5	1.3	1.1	0.85	0.64	47
40	2.2	1.9	1.7	1.4	1.1	0.83	36
30	3.1	2.7	2.3	1.9	1.5	1.2	26
20	4.8	4.2	3.6	3	2.4	1.8	17
10	10	8.8	7.5	6.3	5	3.8	8

T_A
Ambient temp. [°C]

RA ..110S

Load current [A]	Thermal resistance [°C/W]						Power dissipation [W]
	20	30	40	50	60	70	
110	0.43	0.35	0.27	-	-	-	126
90	0.63	0.53	0.42	0.32	-	-	97
80	0.81	0.69	0.57	0.45	0.33	-	84
70	1	0.89	0.75	0.61	0.47	0.33	71
60	1.3	1.2	1	0.83	0.66	0.49	59
50	1.7	1.5	1.3	1.1	0.85	0.64	47
40	2.2	1.9	1.7	1.4	1.1	0.83	36
30	3.1	2.7	2.3	1.9	1.5	1.2	26
20	4.8	4.2	3.6	3	2.4	1.8	17
10	10	8.8	7.5	6.3	5	3.8	8

T_A
Ambient temp. [°C]

Heatsink Selection

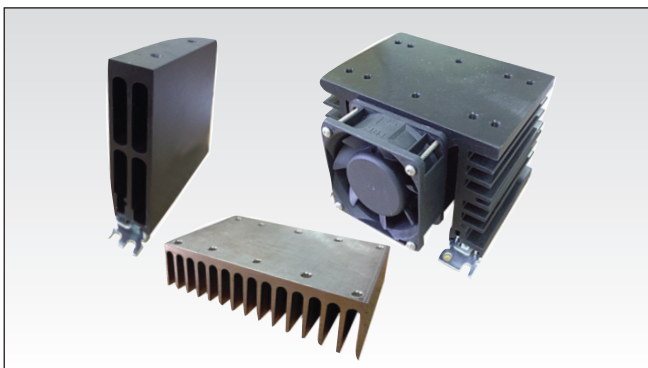

Heatsink Range Overview:

http://www.productselection.net/PDF/UK/ssr_accessories.pdf

Heatsink Selector Tool:

<http://www.productselection.net/heatsink/heatsinkselector.php?LANG=UK>

Ordering Key

RHS..

- Heatsinks and fans
- 5.40°C/W to 0.12°C/W thermal resistance
- DIN, panel or thru wall mounting
- Single or multiple SSR mounting



Dimensions

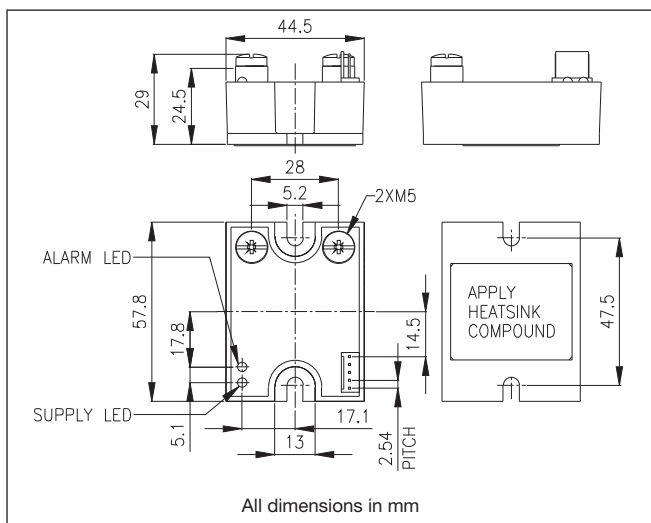

Housing Specifications

Weight	Approx. 110 g
Housing material	Noryl GFN 1, black
Base plate 25, 50 A 90, 110 A	Aluminium, nickel-plated Coper, nickel-plated
Potting compound	Polyurethane
Relay Mounting screws Mounting torque	M5 ≤ 1.5 Nm
Power terminal Mounting screws Mounting torque	M5 x 6 ≤ 2.4 Nm
Control connector	5 pole, centre distance 2.54 mm



Environmental Information

The declaration in this section is prepared in compliance with People’s Republic of China Electronic Industry Standard SJ/T11364-2014: Marking for the Restricted Use of Hazardous Substances in Electronic and Electrical Products.

Part Name	Toxic or Harardous Substances and Elements					
	Lead (Pb)	Mercury (Hg)	Cadmium (Cd)	Hexavalent Chromium (Cr(VI))	Polybrominated biphenyls (PBB)	Polybrominated diphenyl ethers (PBDE)
Power Unit Assembly	x	○	○	○	○	○
○: Indicates that said hazardous substance contained in homogeneous materials fot this part are below the limit requirement of GB/T 26572. X: Indicates that said hazardous substance contained in one of the homogeneous materials used for this part is above the limit requirement of GB/T 26572.						

环境特性

这份申明根据中华人民共和国电子工业标准 SJ/T11364-2014：标注在电子电气产品中限定使用的有害物质

零件名称	有毒或有害物质与元素					
	铅 (Pb)	汞 (Hg)	镉 (Cd)	六价铬 (Cr(VI))	多溴化联苯 (PBB)	多溴联苯醚 (PBDE)
功率单元	x	○	○	○	○	○
○:此零件所有材料中含有的该有害物低于GB/T 26572的限定。 X: 此零件某种材料中含有的该有害物高于GB/T 26572的限定。						





Accessories

Accessories can be ordered pre-assembled with Solid State Relays. These include Heatsinks, DIN rail adaptors, fuses, varistors and spacers.

For further information refer to Accessories datasheets at: www.productselection.net/PDF/UK/SSR_Accessories.pdf

Ribbon Cable Selection

RCS 5-200-1

- R-System cable _____
- No. of wires _____
- Cable length in cm _____
- Termination at one end _____