

Installing EM511 / Installare EM511 / Installation des EM511 / Installer le EM511 / Instalar el EM511 / Installer EM511

1. Mount EM511 on DIN rail.
2. Remove the terminal caps
3. Complete measuring input connections (solution A or B).

1. Montare EM511 su binario DIN.
2. Rimuovere i coprimorsetti
3. Completare le connessioni di ingresso misurazione (soluzione A o B).

1. EM511 auf DIN-Schiene montieren.
2. Anschlussabdeckungen entfernen
3. Anschlüsse an den Messeingängen fertigstellen (Lösung A oder B).

1. Monter EM511 sur un rail DIN.
2. Enlever les cache-bornes
3. Compléter la mesure des connexions d'entrée (solution A ou B).

1. Montar el EM511 en el carril DIN.
2. Quitar los tapones para terminales
3. Completar las conexiones de entrada de medición (solución A o B).

1. Montere EM511 på DIN-skinne.
2. Fjern klemmedækslerne
3. Udfør måling af indgangsforbindelser. (Løsning A eller B)

Un (L-N)	120 ... 240 V (non MID) 230 V (MID)
Voltage tolerance	From 0.8 to 1.15 Un
Frequency	50...60 Hz (non MID) 50 Hz (MID)
Ib/Iref	5 A
I_{max}	45 A

Un (L-N)	120 ... 240 V (non MID) 230 V (MID)
Tolleranza tensione	Da 0,8 a 1,15 Un
Frequenza	50...60 Hz (non MID) 50 Hz (MID)
Ib/Iref	5 A
I_{max}	45 A

Un (L-N)	120 ... 240 V (nicht MID) 230 V (MID)
Spannungstoleranz	Von 0,8 bis 1,15 Un
Frequenz	50...60 Hz (nicht MID) 50 Hz (MID)
Ib/Iref	5 A
I_{max}	45 A

Un (L-N)	120 ... 240 V (non MID) 230 V (MID)
Tolérance de tension	De 0,8 à 1,15 Un
Fréquence	50...60 Hz (non MID) 50 Hz (MID)
Ib/Iref	5 A
I_{max}	45 A

Un (L-N)	120 ... 240 V (no MID) 230 V (no MID)
Tolerancia de tensión	Desde 0,8 hasta 1,15 Un
Frecuencia	50...60 Hz (no MID) 50 Hz (MID)
Ib/Iref	5 A
I_{max}	45 A

Un (L-N)	120 ... 240 V (ikke MID) 230 V (MID)
Spændingstolerance	Fra 0,8 til 1,15 Un
Frekvens	50...60 Hz (ikke MID) 50 Hz (MID)
Ib/Iref	5 A
I_{max}	45 A

4. Connect inputs and digital output, RS485 or M-Bus.
5. Close the terminal caps
6. Seal the terminal caps (MID requirement).
7. Turn on power and check correct operation.
8. Configure EM511.

4. Collegare ingressi e uscita digitale, RS485 o M-Bus.
5. Chiudere i coprimorsetti
6. Sigillare i coprimorsetti (prescrizione MID).
7. Accendere l'alimentazione e controllare che il sistema funzioni correttamente.
8. Configurare EM511.

4. Eingänge und digitalen Ausgang, RS485 oder M-Bus anschließen.
5. Anschlussabdeckungen schließen
6. Die Anschlusskappen versiegeln (MID-Anforderung).
7. Strom einschalten und auf korrekten Betrieb prüfen.
8. Konfiguration des EM511.

4. Connecter les entrées et les sorties numériques, RS485 ou M-Bus.
5. Fermer les cache-bornes
6. Sceller les cache-bornes (exigence MID).
7. Mettre sous tension et contrôler le fonctionnement correct.
8. Configurer EM511.

4. Conectar las entradas y la salida digital, RS485 o M-Bus.
5. Cerrar los tapones para terminales (requisito MID)
6. Sellar los tapones para terminales (requisito MID)
7. Encienda y compruebe el funcionamiento correcto.
8. Configure el EM511.

4. Tilslut indgange og digital udgang, RS485 eller M-Bus.
5. Luk klemmedækslerne
6. Forsegel klemmedækslerne (MID-krav).
7. Tænd for strømmen, og kontrollér den korrekte drift.
8. Konfigurer EM511.

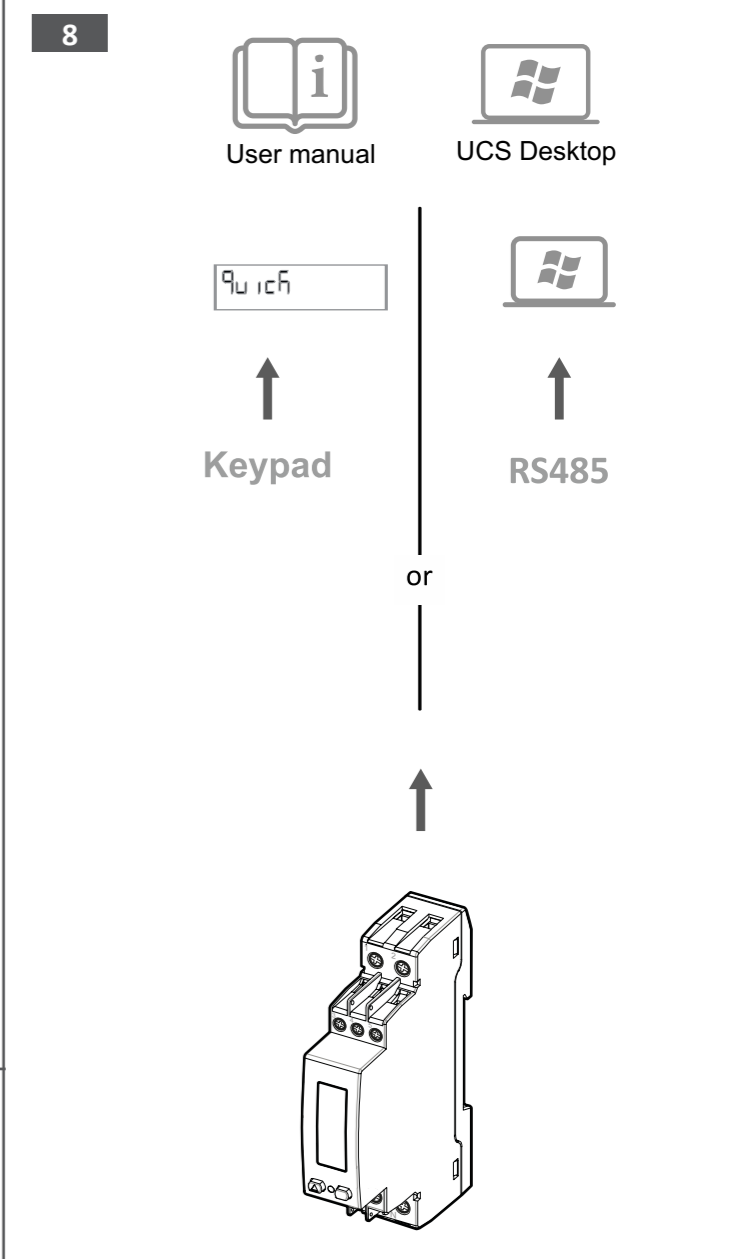
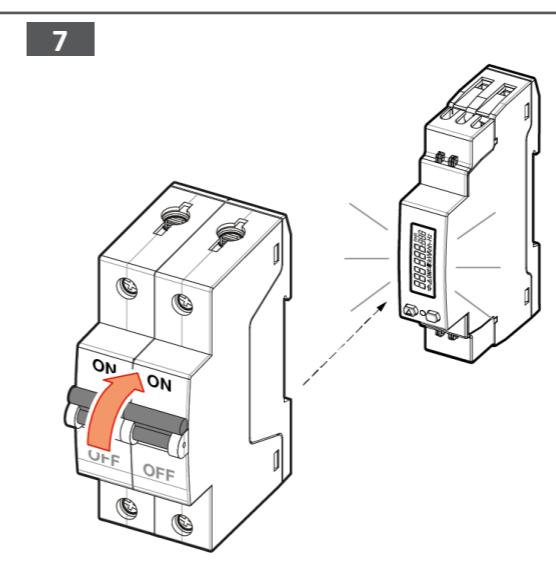
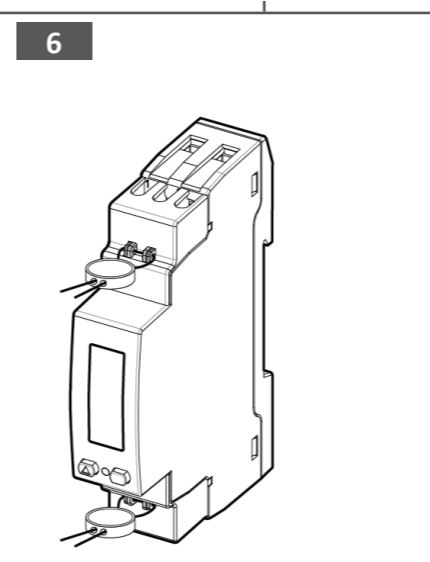
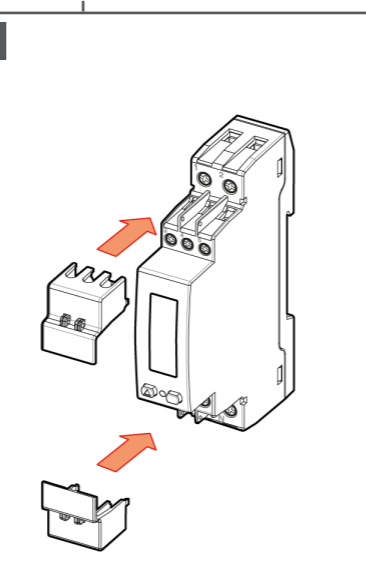
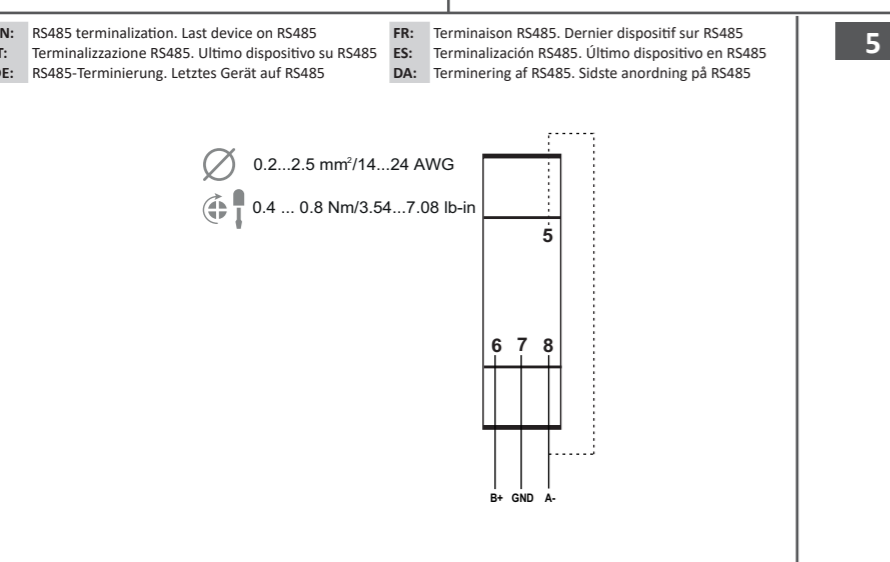
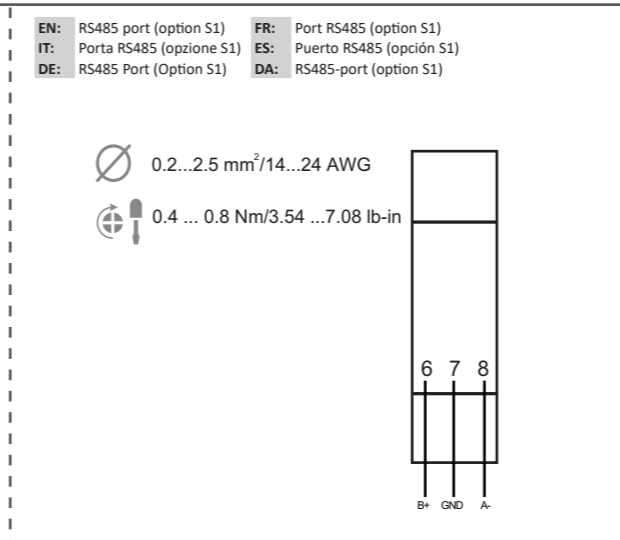
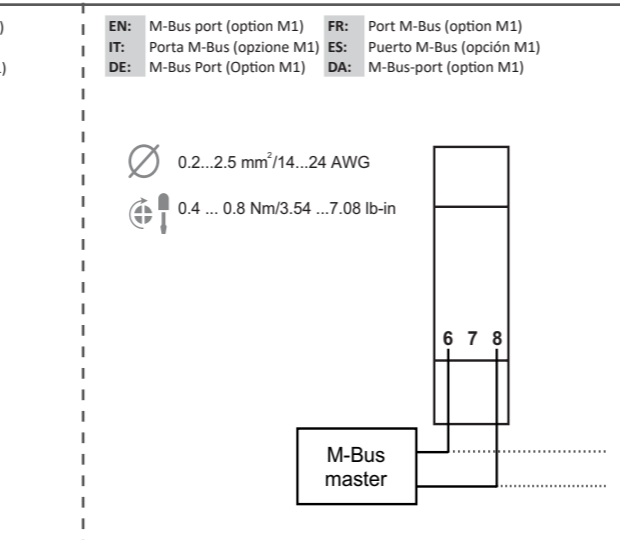
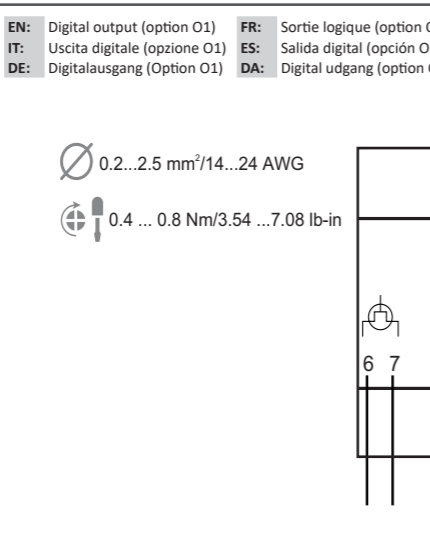
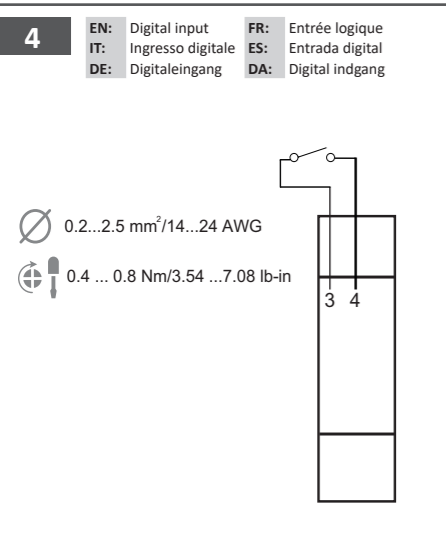
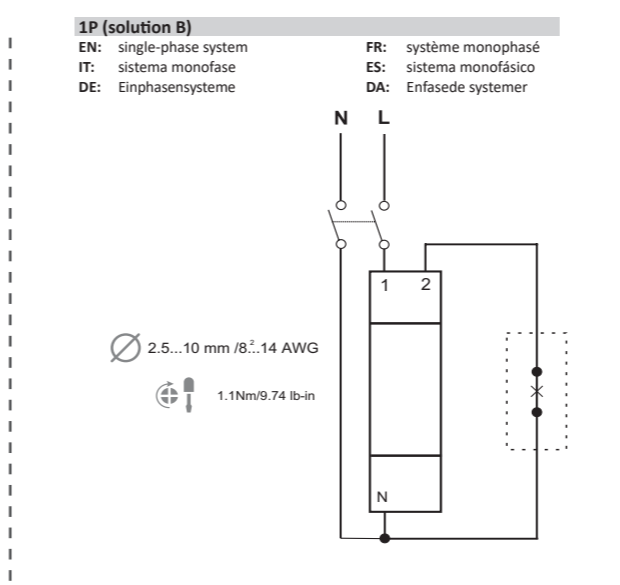
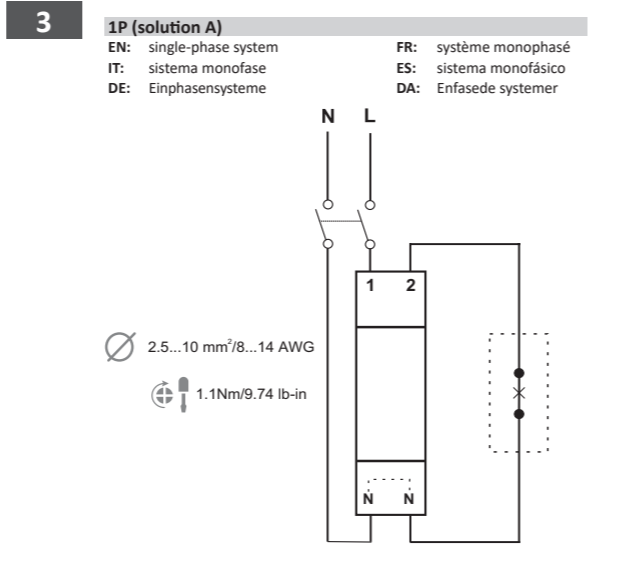
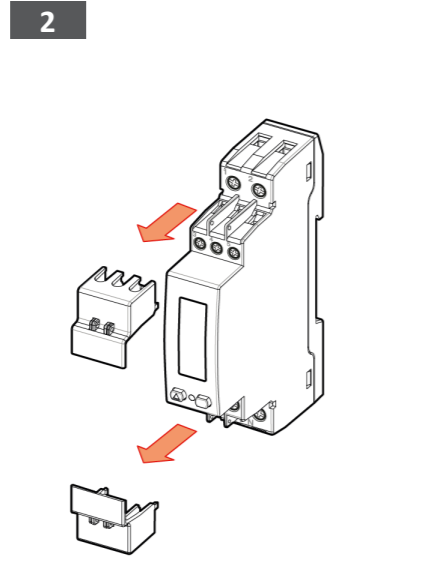
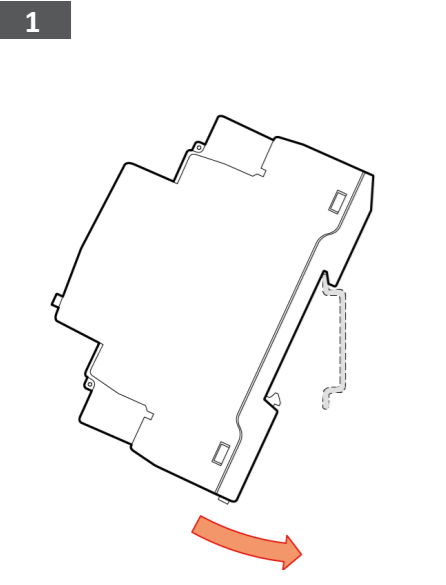
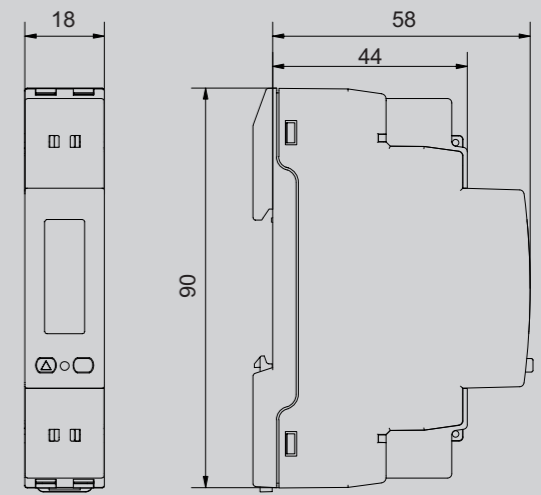

User manual https://www.gavazziautomation.com/images/PIM/MANUALS/ENG/EM511_MAN_ENG.pdf
 UCS Desktop <https://www.gavazziautomation.com/images/PIM/OTHERSTUFF/ucs.zip>



CARLO GAVAZZI
 CARLO GAVAZZI Controls SpA
 via Safforze, 8 32100 Belluno (BL) Italy
 www.gavazziautomation.com
 info@gavazzi-automation.com
 info: +39 0437 355811 / fax: +39 0437 355880



EM511

Installation instruction
Energy analyzer for 1-phase systems

安装说明

用于单相系统的电能分析仪

安裝說明

單相系統用電能分析儀



EN	
Operating temperature	From -25 to +55 °C/from -13 to +131 °F
Storage temperature	From -30 to +70 °C/from -22 to +158 °F
Protection degree	Front: IP40. Terminals: IP20
Overvoltage/Measurement category	III, 4kV
Utilization category	UC1
Altitude	Max 2000 m
Consumption	< 0.6 W/1.8 VA.
Digital output	V _{ON} 2.5 V ac/dc, max 100 mA. V _{OFF} 42 V ac/dc max
Digital input	Contact measuring voltage: 5 V dc +/- 5%. Contact measuring current: 5 mA max
Weight	565 g
<i>Note: R.H. < 90 % non-condensing @ 40 °C / 104 °F.</i>	

简体中文	
工作温度	-25 至 +55 °C/-13 至 +131 °F
存储温度	-30 至 +70 °C/-22 至 +158 °F
防护等级	正面：IP40。端子：IP20
过电压/测量类别	III, 4kV
使用类别	UC1
海拔高度	最高 2000 m
功耗	< 0.6 W/1.8 VA。
数字输出	V _{ON} 2.5 V ac/dc，最大 100 mA。 V _{OFF} 42 V ac/dc 最大
数字输入	触点测量电压：5 V dc +/- 5%。触点测量电流：最大 5 mA
重量	565 g

注意：相对湿度< 90 %，非冷凝，处于 40 °C / 104 °F 时。

繁體中文	
作業溫度	-25 到 +55 °C/-13 到 +131 °F
儲存溫度	-30 到 +70 °C/-22 到 +158 °F
防護等級	正面：IP40。端子：IP20
過電壓/量測類別	III, 4kV
利用類別	UC1
海拔高度	最高 2000 m
消耗量	< 0.6 W/1.8 VA。
數位輸出	V _{ON} 2.5 V ac/dc，最大 100 mA。 V _{OFF} 42 V ac/dc 最大
數位輸入	接觸量測電壓：5 V dc +/- 5%。接觸量測電流：最大 5 mA
重量	565 g

註：相對濕度< 90 %，未凝結，處於 40 °C / 104 °F 時。

ENGLISH	
Warnings	
 DANGER! Live parts. Heart attack, burns and other injuries.	
<ul style="list-style-type: none">Disconnect the power supply and loads before connecting/disconnecting the electrical wires. Only use the analyzer at the specified voltage and current. The analyzer should only be installed by qualified personnel experienced in working in safety. Access to the terminals is reserved for qualified personnel for maintenance operations. The system installer is liable for the safety of any system that includes the analyzer	
NOTICE: <i>only use the analyzer at the specified voltage and current to avoid permanent damage.</i>	
NOTICE: <i>no one is authorized to open the analyzer. This operation is reserved exclusively for CARLO GAVAZZI technical service personnel. Protection may be impaired if the instrument is used in a manner not specified by the manufacturer.</i>	
 This manual is an integral part of the product. It must be consulted for analyzer installation. It must be kept in good condition and in a clean location accessible to all operators.	
Cleaning	
Use a slightly dampened cloth to clean the display. Do not use abrasives or solvents.	
Responsibility for disposal	
 The product must be disposed of at the relative recycling centers specified by the government or local public authorities. Correct disposal and recycling will contribute to the prevention of potentially harmful consequences to the environment and persons.	
Service and warranty	
In the event of malfunction, fault, requests for information or to purchase accessory modules, contact the CARLO GAVAZZI branch or distributor in your country. Installation and use of analyzers other than those indicated in the provided instructions void the warranty.	

NOTICE: *只可在額定电压和电流下使用分析仪，以避免发生永久性损坏。*

NOTICE: *任何人均不得拆开分析仪。只有 CARLO GAVAZZI 的技术服务人员才可进行此项操作。保护可能会因仪器的使用方式而受到损害，可能会损害保护功能。*

 This manual is an integral part of the product. It must be consulted for analyzer installation. It must be kept in good condition and in a clean location accessible to all operators.

Cleaning

Use a slightly dampened cloth to clean the display. Do not use abrasives or solvents.

Responsibility for disposal

 The product must be disposed of at the relative recycling centers specified by the government or local public authorities. Correct disposal and recycling will contribute to the prevention of potentially harmful consequences to the environment and persons.

Service and warranty

In the event of malfunction, fault, requests for information or to purchase accessory modules, contact the CARLO GAVAZZI branch or distributor in your country. Installation and use of analyzers other than those indicated in the provided instructions void the warranty.

简体中文

警告

 **危险!** 带电部件。可能导致心脏病发作、烧伤及其他伤害。

• 在连接/断开电线之前，请先断开电源和所有负荷。

• 只可在額定电压和电流下使用分析仪。

• 分析仪只能由具备安全工作经验的合格人员安装。

• 只有合格人员才能使用端子，以进行维护操作。

• 系統安裝人員負責保證任何包含分析仪的系統的安全性

注意：只可在額定电压和电流下使用分析仪，以避免发生永久性损坏。

注意：任何人均不得拆开分析仪。只有 CARLO GAVAZZI 的技术服务人员才可进行此项操作。如果以制造商未指定的方式使用仪器，可能会损害保护功能。

 本手册是产品不可或缺的一部分。安装分析仪时必须查阅本手册。必须将其妥善保存在所有操作人员都可轻松取得的显眼位置。

清洁

使用略微蘸湿的布清洁显示屏。请勿使用研磨剂或溶剂。

处置责任

 本产品必须在政府或当地公共机构所指定的相关回收中心进行处置。正确处置和回收可以防止对环境 and 人身安全造成潜在危害。

维修和保修

如果发生故障、错误，或需要了解信息或购买附属模块，请联系 CARLO GAVAZZI 在您所在国家/地区的分公司或经销商。若未按照附带说明书所载方式安装和使用分析仪，将导致保修失效。

繁體中文

警告

 **危險!** 帶電零件。可能導致心臟病發作、燒傷及其他傷害。

• 在連接/斷開電線之前，請先斷開電源和負載。

• 只可在規定電壓和電流下使用分析儀。

• 分析儀只能由具備安全工作經驗的合格人員安裝。

• 僅限合格人員使用端子，以進行維護操作。

• 系統安裝人員負責保證任何包含分析儀的系統的安全性

注意：只可在規定電壓和電流下使用分析儀，以避免發生永久性損壞。

注意：任何人都不得拆開分析儀。此類操作必須由 CARLO GAVAZZI 技術服務人員進行。如果不依照製造商指定的方式使用儀器，可能會對防護等級造成損害。

 本手冊是產品不可或缺的一部分。安裝分析儀時必須查閱本手冊。請務必將手冊妥善存放在所有操作人員都能方便拿取的顯眼位置。

清潔

使用微濕抹布清潔顯示器。請勿使用研磨劑或溶劑。

廢棄責任

 必須將本產品交由政府或當地公共機關指定之相關回收中心進行廢棄。請按照正確方式廢棄和回收，避免對環境與個人造成潛在危害。

服務與保固

若功能異常、發生故障、需要資訊或購買配件模組，請聯絡您所在國家/地區的 CARLO GAVAZZI 分公司。

若未按照附帶說明書所載方式安裝和使用分析儀，將導致保固失效。

UL notes:

Terminal L,N: Use minimum 70°C Copper or Copper-Clad Aluminum conductors, wire rated min. 240Vac, wire size 8-14 AWG stranded or solid, tightening torque 1.1Nm/ 9.74 lb-in.

When installed shall be provided with one external UL fuse category JDDZ, class CC, max. 400mA, min. 240Vac located on mains neutral conductor.

UL 备注:

端子 L、N：使用最低 70° C 的筒或铜包铝导体，接线额定规格至少 240Vac，接线尺寸为 8–14 AWG 分股线或实心线，紧固扭矩为 1.1Nm/ 9.74 lb-in。

安装时，应提供一个外置 UL 熔断器，规格要求为：类别 JDDZ，等级 CC，最大 400mA，最低 240Vac，安装在主电源中性线上。

UL 說明:

終端 L、N：使用最低 70° C 的銅或銅包鋁導線，電線額定最小交流電壓為 240Vac，尺寸為 8-14 AWG 的紋線或實心線，擰緊扭矩為 1.1Nm/ 9.74 lb-in。

安裝時，應在電源中性導線上提供一個外部 UL 保險絲，類別 JDDZ，等級 CC，最大電流為 400mA，最小交流電壓為 240Vac。

Installing EM511 / 安裝 EM511 / 安裝 EM511

1. Mount EM511 on DIN rail.
2. Remove the terminal caps
3. Complete measuring input connections (solution A or B).

1. 將 EM511 安裝在 DIN 導軌上。
2. 移除端子蓋
3. 完成測量輸入連接 (方案 A 或 B)。

1. 將 EM511 安裝於 DIN 導軌上。
2. 取下端子蓋。
3. 完成量測輸入連接 (方案 A 或 B)。

Un (L-N)	120 ... 240 V (non MID) 230 V (MID)
Voltage tolerance	From 0.8 to 1.15 Un
Frequency	50...60 Hz (non MID) 50 Hz (MID)
Ib/Iref	5 A
I_{max}	45 A

Un (L-N)	120 ...240 V (非 MID) 230 V (MID)
电压容差	0.8 至 1.15 Un
频率	50...60 Hz (非 MID) 50 Hz (MID)
Ib/Iref	5 A
I_{max}	45 A

Un (L-N)	120 ...240 V (非 MID) 230 V (MID)
電壓公差	從 0.8 到 1.15 Un
頻率	50...60 Hz (非 MID) 50 Hz (MID)
Ib/Iref	5 A
I_{max}	45 A

4. Connect inputs and digital output, RS485 or M-Bus.
5. Close the terminal caps
6. Seal the terminal caps (MID requirement).
7. Turn on power and check correct operation.
8. Configure EM511.

4. 連接輸入和數字輸出、RS485 或 M-Bus。
5. 關閉端子蓋
6. 密封端子蓋 (MID 要求)。
7. 打開電源，檢查是否正確運作。
8. 配置 EM511。

4. 連接輸入與數位輸出、RS485 或 M-Bus。
5. 蓋上端子蓋
6. 密封端子蓋 (MID 規定)。
7. 打開電源，檢查是否正確運作。
8. 設定 EM511。

