



**Installing EM530 RG / Installare EM530 RG / Installation des EM530 RG / Installer le EM530 RG / Instalar el EM530 RG / Installer EM530 RG**

1. Mount EM530 RG on DIN rail.
  2. Open terminal caps.
  3. Complete measuring input connections.
- |                            |                     |
|----------------------------|---------------------|
| <b>U<sub>n</sub> (L-N)</b> | 120 ... 240 V       |
| <b>U<sub>n</sub> (L-L)</b> | 208...415 V         |
| <b>Voltage tolerance</b>   | -20 +15%            |
| <b>Frequency</b>           | 50...60 Hz          |
| <b>Current range</b>       | 600 A 1200 A 2400 A |
| <b>I<sub>max</sub></b>     | 720 A 1440 A 2880 A |
4. Close and seal the terminal caps.
  5. Connect the inputs and communication interfaces:
    - A: Digital input
    - B: Digital output
    - C: M-Bus port
    - D: RS485 port
  6. Turn on power.
  7. Configure EM530 RG.

1. Montare EM530 RG su guida DIN.
  2. Aprire i coprimorsetti.
  3. Eseguire i collegamenti degli ingressi di misura.
- |                               |                     |
|-------------------------------|---------------------|
| <b>U<sub>n</sub> (L-N)</b>    | 120 ... 240 V       |
| <b>U<sub>n</sub> (L-L)</b>    | 208...415 V         |
| <b>Tolleranza tensione</b>    | -20 +15%            |
| <b>Frequenza</b>              | 50...60 Hz          |
| <b>Intervallo di corrente</b> | 600 A 1200 A 2400 A |
| <b>I<sub>max</sub></b>        | 720 A 1440 A 2880 A |
4. Chiudere e sigillare i coprimorsetti.
  5. Collegare gli ingressi e le interfacce di comunicazione:
    - A: Ingresso digitale
    - B: Uscita digitale
    - C: Porta M-Bus
    - D: Porta RS485
  6. Accendere l'alimentazione.
  7. Configurare l'EM530 RG.

1. EM530 RG auf DIN-Schiene montieren.
  2. Anschlussabdeckungen öffnen.
  3. Eingangsanschlüsse komplett durchmessen.
- |                            |                     |
|----------------------------|---------------------|
| <b>U<sub>n</sub> (L-N)</b> | 120 ... 240 V       |
| <b>U<sub>n</sub> (L-L)</b> | 208...415 V         |
| <b>Spannungstoleranz</b>   | -20 +15%            |
| <b>Frequenz</b>            | 50...60 Hz          |
| <b>Strombereich</b>        | 600 A 1200 A 2400 A |
| <b>I<sub>max</sub></b>     | 720 A 1440 A 2880 A |
4. Die Anschlusskappen schließen und abdichten.
  5. Verbinden Sie die Eingänge und Kommunikationsschnittstellen:
    - A: Digitaleingang
    - B: Digitalausgang
    - C: M-Bus-port
    - D: RS485-port
  6. Strom einschalten.
  7. EM530 RG konfigurieren.

1. Monter EM530 RG sur un rail DIN.
  2. Ouvrir les cache-bornes.
  3. Compléter la mesure des connexions d'entrée.
- |                             |                     |
|-----------------------------|---------------------|
| <b>U<sub>n</sub> (L-N)</b>  | 120 ... 240 V       |
| <b>U<sub>n</sub> (L-L)</b>  | 208...415 V         |
| <b>Tolérance de tension</b> | -20 +15%            |
| <b>Fréquence</b>            | 50...60 Hz          |
| <b>Plage de courant</b>     | 600 A 1200 A 2400 A |
| <b>I<sub>max</sub></b>      | 720 A 1440 A 2880 A |
4. Fermer et sceller les cache-bornes.
  5. Connectez les entrées et les interfaces de communication:
    - A: Entrée numérique
    - B: Sortie numérique
    - C: Port M-Bus
    - D: Port RS485
  6. Allumez l'appareil.
  7. Configurer EM530 RG.

1. Montar el EM530 RG en el carril DIN.
  2. Abrir los tapones para terminales.
  3. Realizar las conexiones de las entradas de medición.
- |                              |                     |
|------------------------------|---------------------|
| <b>U<sub>n</sub> (L-N)</b>   | 120 ... 240 V       |
| <b>U<sub>n</sub> (L-L)</b>   | 208...415 V         |
| <b>Tolerancia de tensión</b> | -20 +15%            |
| <b>Frecuencia</b>            | 50...60 Hz          |
| <b>Rango de corriente</b>    | 600 A 1200 A 2400 A |
| <b>I<sub>max</sub></b>       | 720 A 1440 A 2880 A |
4. Cerrar y sellar los tapones para terminales.
  5. Conecte las entradas y las interfaces de comunicación:
    - A: Entrada digital
    - B: Salida digital
    - C: Puerto M-Bus
    - D: Puerto RS485
  6. Encender la alimentación.
  7. Configurar el EM530 RG.

1. Monter EM530 RG på DIN-skinne.
  2. Åbn klemmedæksler.
  3. Udfør måling af indgangsforbindelser.
- |                            |                     |
|----------------------------|---------------------|
| <b>U<sub>n</sub> (L-N)</b> | 120 ... 240 V       |
| <b>U<sub>n</sub> (L-L)</b> | 208...415 V         |
| <b>Spændingstolerance</b>  | -20 +15%            |
| <b>Frekvens</b>            | 50...60 Hz          |
| <b>Strømråde</b>           | 600 A 1200 A 2400 A |
| <b>I<sub>max</sub></b>     | 720 A 1440 A 2880 A |
4. Luk og forsegl terminalhætterne.
  5. Tilslut indgangene og kommunikationsgrænsefladerne:
    - A: Digital indgang
    - B: Digital udgang
    - C: M-Bus-port
    - D: RS485-port
  6. Tænd for strømmen.
  7. Konfigurer EM530 RG.

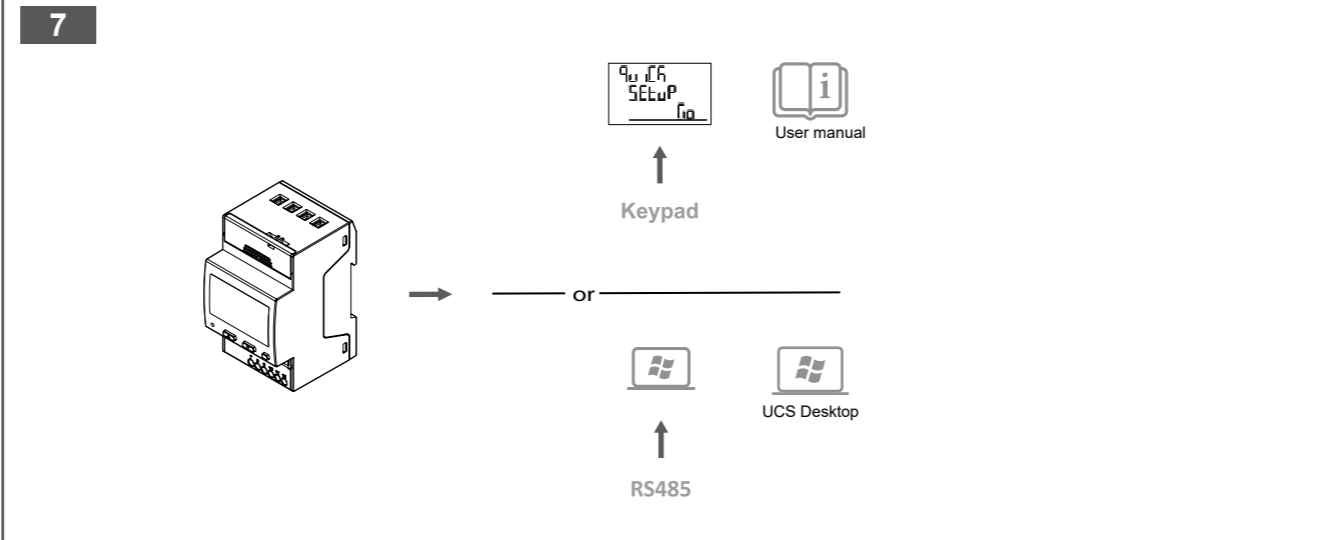
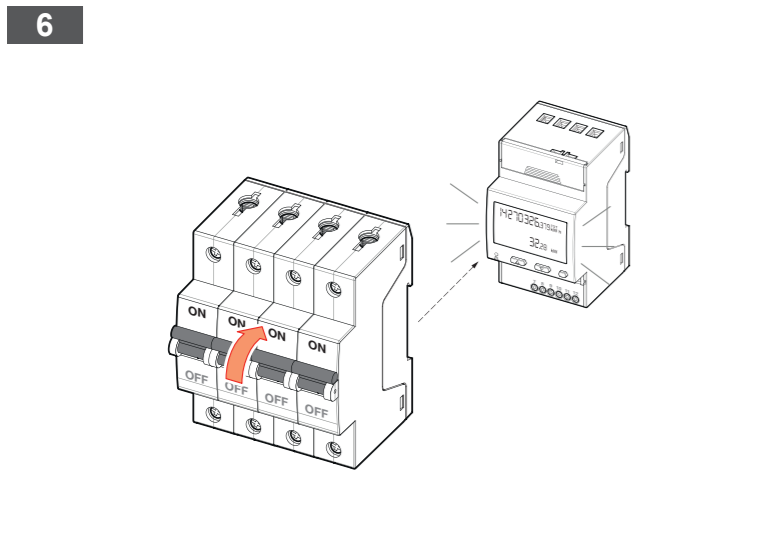
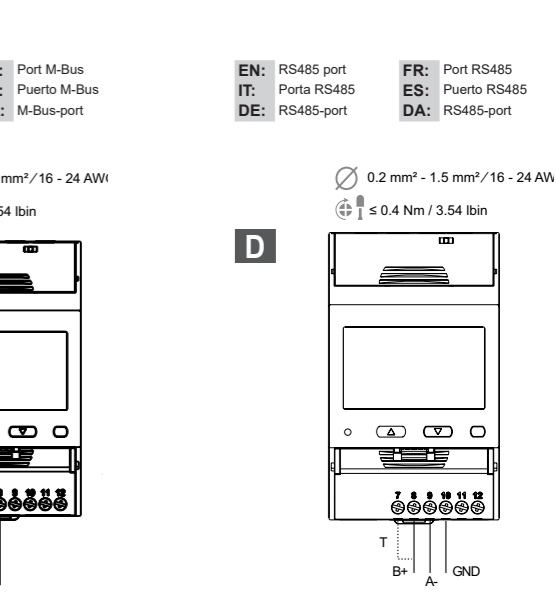
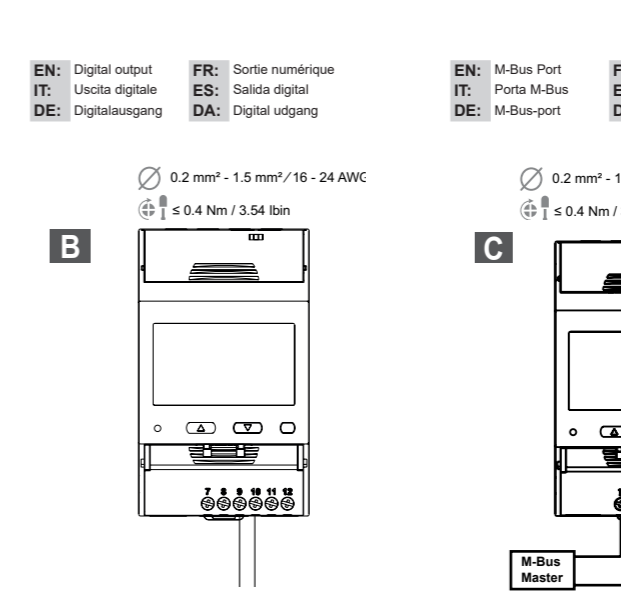
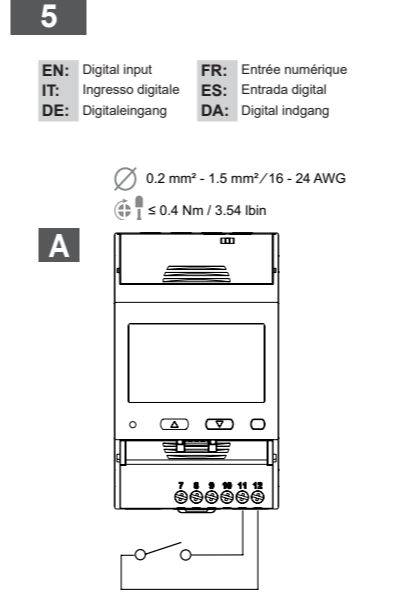
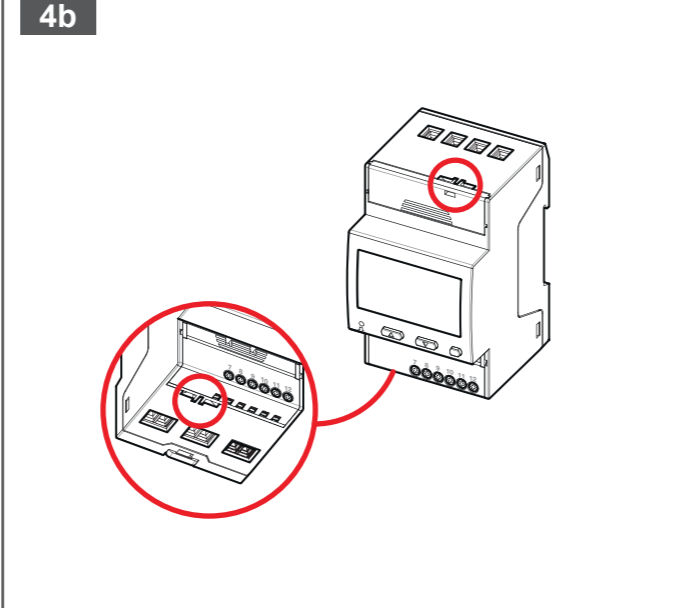
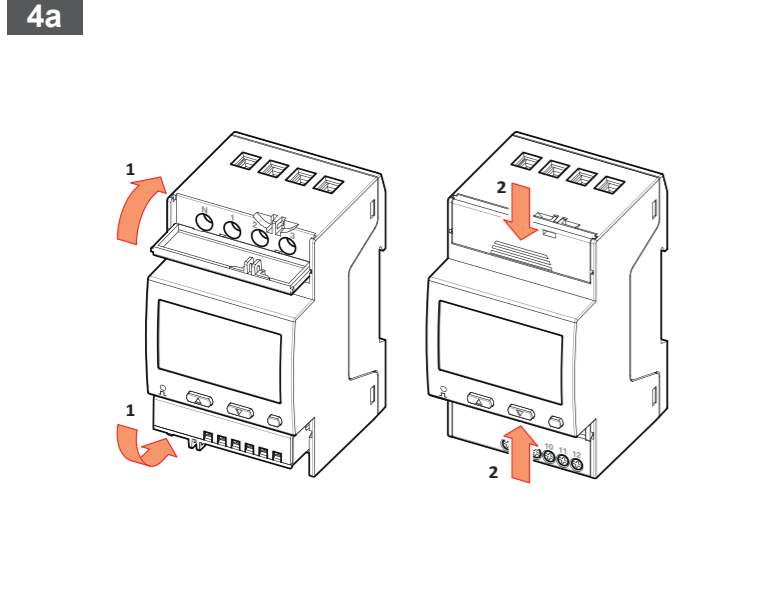
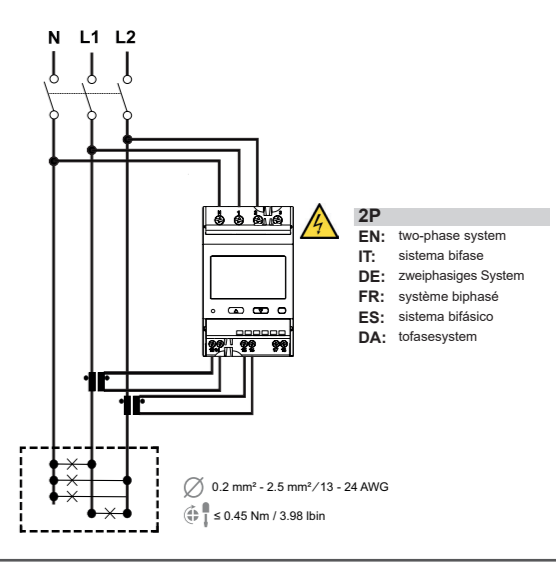
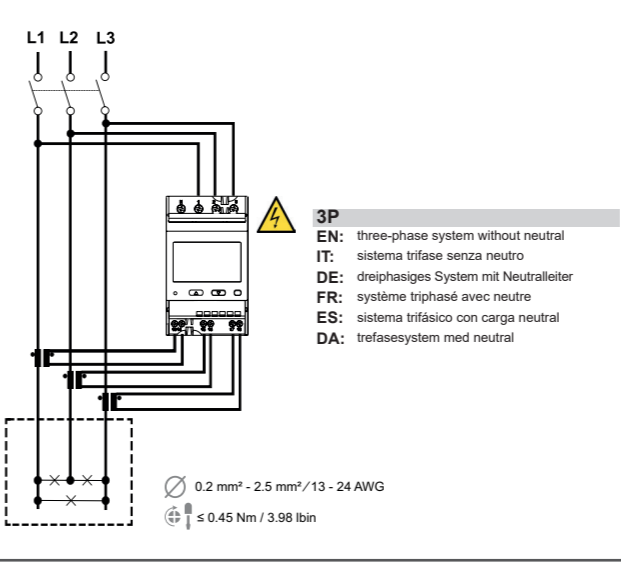
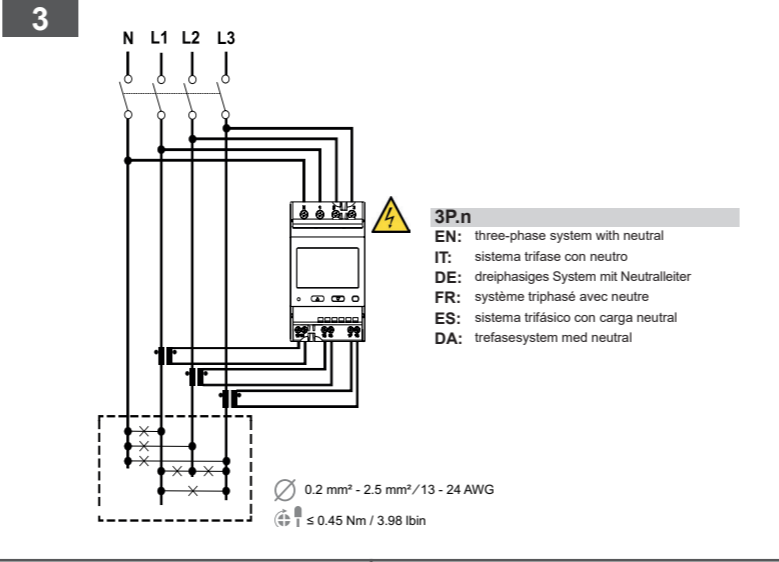
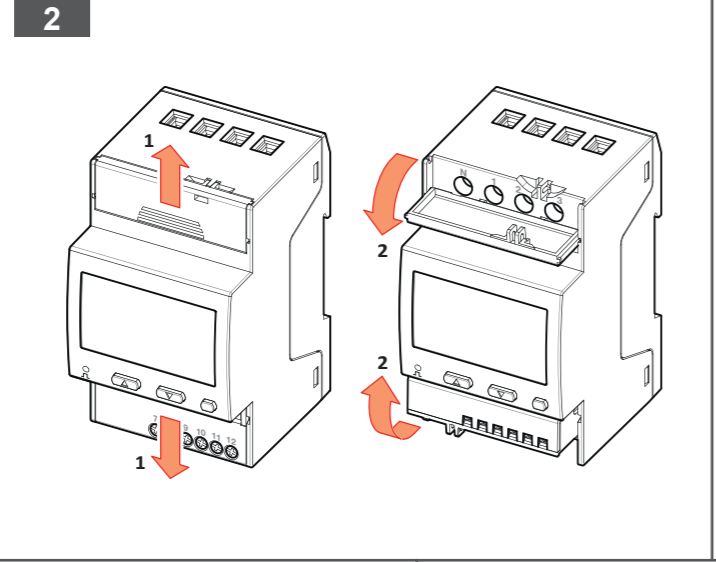
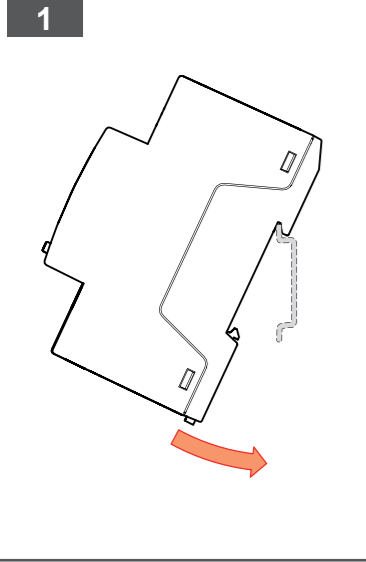
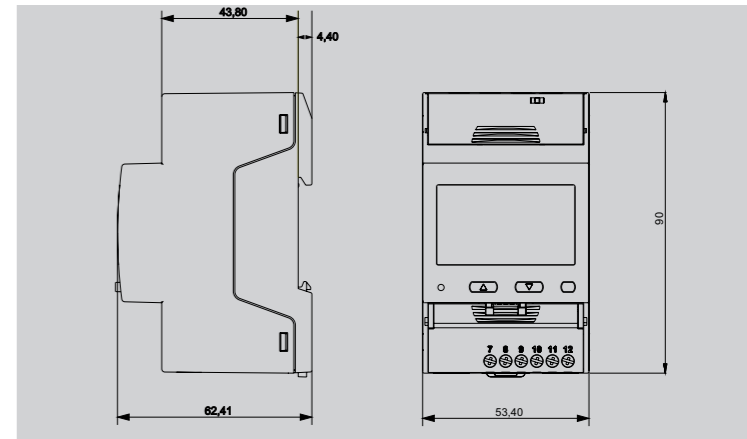

User manual: [https://www.gavazziautomation.com/images/PIM/MANUALS/ENG/EM500\\_IM\\_USE.pdf](https://www.gavazziautomation.com/images/PIM/MANUALS/ENG/EM500_IM_USE.pdf)

UCS Desktop: <https://www.gavazziautomation.com/images/PIM/OTHERSTUFF/ucs.zip>

**CARLO GAVAZZI**

CARLO GAVAZZI Controls SpA  
 via Safforze, 8 32100 Belluno (BL) Italy  
 www.gavazziautomation.com  
 info@gavazzi-automation.com  
 info: +39 0437 355811 / fax: +39 0437 355880

www.gavazziautomation.com    19/02/2026 | 8022426 | COPYRIGHT ©2026



CARLO GAVAZZI

## EM530 RG

### EN - Installation instruction

Power analyzer for three-phase and two-phase systems

### ZH-SC - 安装说明

适用于三相和两相系统的功率分析仪

### ZH-TC - 安裝說明

適用於三相和雙相系統的功率分析儀



<b>EN</b>	
<b>Operating temperature</b>	From -25 to +55 °C/from -13 to +131 °F
<b>Storage temperature</b>	From -25 to +70 °C/from -13 to +158 °F
<b>Protection degree (not UL evaluated)</b>	IP40 and IP51 (just in a distribution board with IP51 degree)
<b>Overvoltage/Measurement category</b>	III, 4kV rated Impulse voltage
<b>Protective class</b>	II
<b>Altitude</b>	Max 2000 m
<b>Consumption</b>	<1.3 W/2.6 VA (W value not UL evaluated)
<b>Digital input</b>	Contact measuring voltage: 5 V dc +/- 5%. Contact measuring current: 5 mA max
<b>Weight</b>	180 g
<i>Note: R.H. &lt; 90<span> </span>% non-condensing @ 40<span> </span>°C / 104<span> </span>°F.</i>	

<b>ZH-SC</b>	
<b>工作溫度</b>	-25 至 +55 °C/-13 至 +131 °F
<b>存儲溫度</b>	-25 至 +70 °C/-13 至 +158 °F
<b>防护等级 (未经 UL 评估)</b>	IP40 和 IP51 (仅用于 IP51 等级的配电板)
<b>过电压/测量类别</b>	III, 4kV 额定脉冲电压
<b>防护等级</b>	II
<b>海拔高度</b>	最高 2000 m
<b>功耗</b>	<1.3 W/2.6 VA (W 值未经过 UL 评估)
<b>数字输入</b>	触点测量电压：5 V dc +/- 5%。 触点测量电流：最大 5 mA
<b>重量</b>	180 g
<i>备注：相对湿度&lt; 90<span> </span>% 非冷凝 @ 40<span> </span>°C / 104<span> </span>°F。</i>	

<b>ZH-TC</b>	
<b>作業溫度</b>	-25 到 +55 °C/-13 到 +131 °F
<b>保存溫度</b>	-25 到 +70 °C/-13 到 +158 °F
<b>防護等級 (未經 UL 評估)</b>	IP40 和 IP51 (僅用於 IP51 等級的配電板)
<b>過電壓/量測類別</b>	III, 4kV 額定脈衝電壓
<b>防護等級</b>	II
<b>海拔高度</b>	最高 2000 m
<b>消耗量</b>	<1.3 W/2.6 VA (W 值未經過 UL 評估)
<b>數位輸入</b>	接觸量測電壓：5 V dc +/- 5%。 接觸量測電流：最大 5 mA
<b>重量</b>	180 g
<i>備註：相對濕度&lt; 90<span> </span>% 未凝結 @ 40<span> </span>°C / 104<span> </span>°F。</i>	

<b>ENGLISH</b>	
----------------	--

#### Warnings

-   **DANGER!** Live parts. Heart attack, burns and other injuries.
- Disconnect the power supply and loads before connecting/disconnecting the electrical wires and installing or servicing current transformers.
- Only use the analyzer at the specified voltage and current.
- The analyzer should only be installed by qualified personnel experienced in working in safety.
- Access to the terminals is reserved for qualified personnel for maintenance operations.

**NOTICE:** The system installer is liable for the safety of any system that includes the analyzer

**NOTICE:** Always use electrical wires according to all applicable local and international regulations.

**NOTICE:** only use the analyzer at the specified voltage and current to avoid permanent damage.

**NOTICE:** no one is authorized to open the analyzer. This operation is reserved exclusively for CARLO GAVAZZI technical service personnel. Protection may be impaired if the instrument is used in a manner not specified by the manufacturer.

 This manual is an integral part of the product. It must be consulted for analyzer installation. It must be kept in good condition and in a clean location accessible to all operators.

#### Cleaning

Use a slightly dampened cloth to clean the display. Do not use abrasives or solvents.

#### Responsibility for disposal

 The product must be disposed of at the relative recycling centers specified by the government or local public authorities. Correct disposal and recycling will contribute to the prevention of potentially harmful consequences to the environment and persons.





#### Service and warranty

In the event of malfunction, fault, requests for information or to purchase accessory modules, contact the CARLO GAVAZZI branch or distributor in your country. Installation and use of analyzers other than those indicated in the provided instructions void the warranty.

#### Notes

- The instrument must be installed taking care of leaving the external disconnecting device easily accessible.
- The current transformers may not be installed in equipment where they exceed 75 percent of the wiring space of any cross-sectional area within the equipment.
- Restrict installation of current transformer in an area where it would block ventilation openings.
- Restrict installation of current transformer in an area of breaker arc venting.
- Secure current transformer and route conductors so that they do not directly contact live terminals or bus.
- An external switch or circuit-breaker that must be mounted near the instrument is required.
- For use with Current Sensors rated for basic Insulation.
- To be used in a pollution degree 2 or better environment only
- Indoor use only



#### Display icons

Symbol	Description
	<b>ALARM (blinking icon):</b> the value of the variable has exceeded the threshold set.
 	<b>WIRING ERROR (steady icons):</b> a wiring fault has been detected, the control operates correctly if the selected system is 3Pn and for each phase: <ul style="list-style-type: none"><li>the power is positive (imported),</li> <li>PF &gt; 0.7 L or PF &gt; 0.96 C.</li></ul> For problem solutions, see “EM500 IM wiring solutions”
	Serial communication state (reception / transmission)

	The association of the phase terminal or the direction of the currents have been modified via UCS software to correct virtually a wiring fault. To view the current setup of the terminals, access the info screens ( MENU > INFO > TERMINAL).
---	--

<b>简体中文</b>	
-------------	--

#### 警告

  **危险!** 带电部件。可能导致心脏病发作、烧伤及其他伤害。

- 在连接/断开电线之前，请先断开电源和所有负荷。
- 只可在规定电压和电流下使用分析仪。
- 分析仪只能由具备安全工作经验的合格人员安装。
- 只有合格人员才能使用端子，以进行维护操作。
- 系统安装人员负责保证任何包含分析仪的系统的安全性

**注意：**只可在規定電壓和電流下使用分析儀，以避免發生永久性損壞。

**注意：**務必使用符合当地和国际规范要求的电气线材。

**注意：**任何人都不得拆开分析仪。只有 CARLO GAVAZZI 的技术服务人员才可进行此项操作。如果以制造商未指定的方式使用仪器，可能会损害保护功能。

 本手册是产品不可或缺的一部分。安装分析仪时必须查阅本手册，必须将其妥善保存在所有操作人员都可轻松取得的显眼位置。

#### 清洁

使用略微潮湿的布清洁显示屏。请勿使用研磨剂或溶剂。

#### 处置责任

 本产品必须在政府或当地公共机构所指定的相关回收中心进行处置。正确处置和回收可以防止对环境和个人安全造成潜在危害。

#### 维修和保修

如果发生故障、错误，或需要了解信息或购买附属模块，请联系 CARLO GAVAZZI 在您所在国家/地区的分公司或经销商。若未按照附带说明书所载方式安装和使用分析仪，将导致保修失效。

**注**

- 仪表安装时必须注意保证相应外部断开装置处于方便操作的位置。
- 不得将电流互感器安装在其空间占用在设备内超过可用接线空间或任意横截面积的 75% 的设备之中。
- 应限制将电流互感器安装在会导致其通风口受阻的位置。
- 应限制将电流互感器安装在会出现断路器电弧疏导的位置。
- 应固定电流互感器，并布置导线走向以确保不会直接接触带电端子或总线。
- 要求安装一个必须安装在仪器附近的外部开关或断路器。
- 用于搭配额定用于基础绝缘的电流传感器。
- 仅可用于污染等级 2 或条件更佳的场所
- 仅可用于室内

<b>繁體中文</b>	
-------------	--

#### 警告

  **危險!** 帶電零件。可能導致心臟病發作、燒傷及其他傷害。

- 在連接/斷開電線之前，請先斷開電源和負載。
- 只可在規定電壓和電流下使用分析儀。
- 分析儀只能由具備安全工作經驗的合格人員安裝。
- 僅限合格人員使用端子，以進行維護操作。
- 系統安裝人員負責保證任何包含分析儀的系統的安全性

**注意：**只可在規定電壓和電流下使用分析儀，以避免發生永久性損害。

**注意：**始終依所有適用的當地和國際法規使用電線。

**注意：**任何人都不得拆開分析儀。此類操作必須由 CARLO GAVAZZI 技術服務人員進行。如果不依照製造商指定的方式使用儀器，可能會對防護等級造成損害。

 本手冊是產品不可或缺的一部分。安裝分析儀時必須查閱本手冊。請務必將手冊妥善存放在所有操作人員都能方便拿取的顯眼位置。

#### 清潔

使用微濕抹布清潔顯示器。請勿使用研磨劑或溶劑。

#### 廢棄責任

 必須將本產品交由政府或當地公共機關指定之相關回收中心進行廢棄。請按照正確方式廢棄和回收，避免對環境與個人造成潛在危害。

#### 服務與保固

若功能異常、發生故障、需要資訊或購買配件模組，請聯絡您所在國家/地區的 CARLO GAVAZZI 分公司。若未按照附帶說明書所載方式安裝和使用分析儀，將導致保固失效。

#### 附註

- 安裝本儀器時，必須注意要易於接觸外部斷開裝置。
- 在比流器安裝所在的設備內，比流器不得超過設備內任何截面積接線空間的 75%。
- 限制將比流器安裝在會堵塞通風口的區域。
- 限制將比流器安裝在斷路器電弧排氣的區域。
- 固定比流器並鋪設導線，使其不直接接觸帶電端子或匯流排。
- 需要在本儀器附近安裝外部開關或断路器。
- 用於與額定基本絕緣的電流感測器一起使用。
- 只能在污染等級為 2 或更好的環境中使用。
- 僅限室內使用

**Additional UL notes:**

- For use with Listed or R/C Energy Monitoring Current Sensors rated for basic Insulation.
- Auxiliary inputs/outputs (Digital input, Digital output, RS485, M-Bus) must be connected only to Limited-Energy Circuit in accordance with UL/CSA 61010-1 or Class 2 supply source which complies with the National Electrical Code (NEC), NFPA 70, Clause 725.121 and Canadian Electrical Code (CEC), Part I, C22.1
- Evaluated as open type device; it is intended to be installed inside a dedicated NRTL certified fire/electrical enclosure (overall enclosure) or inside end-product equipment enclosure; it is not intended for retrofit installations in the enclosure of switchgears or panel boards.

#### 額外 UL 备注:

- 用于搭配列出的或额定用于基础绝缘的 R/C 能耗监测电流互感器。
- 辅助输入/输出（数字输入、数字输出、RS485、M-Bus）必须仅连接至符合 UL/CSA 61010-1 要求的有限能量电路，或符合美国电气规范（NEC）NFPA 70 第 725.121 条以及加拿大电气规范（CEC）第 1 部分 C22.1 要求的 2 类电源。
- 作为开放式设备评估；该设备设计应安装在经 NRTL 认证的专用防火电器机柜（整体柜）内或最终设备机柜内；该设备设计不可通过改造安装于开关设备或面板机柜内。

#### 其他 UL 說明:

- 用於與額定基本絕緣的列名或 R/C 能量監測電流感測器一起使用。
- 輔助輸入/輸出（數位輸入、數位輸出、RS485、M-Bus）必須僅連接到符合 UL/CSA 61010-1 的限能電路或符合美國國家電工法規（NEC），NFPA 70，條款 725.121 和加拿大電工法規（CEC），第 1 部分 C22.1 的 2 級電源
- 評估為開放式裝置；旨在安裝在經 NRTL 認證的專用防火/電氣外殼（整體外殼）或最終產品設備外殼內；不適用於在開關設備或配電盤外殼中進行改造安裝。

**Installing EM530 RG / 安裝 EM530 RG / 安裝 EM530 RG**

- |   |  |  |
|---|--|--|
| <ol style="list-style-type: none"> <li>Mount EM530 RG on DIN rail.</li> <li>Open terminal caps.</li> <li>Complete measuring input connections.</li> </ol> | <ol style="list-style-type: none"> <li>將 EM530 RG 安裝在 DIN 導軌上。</li> <li>打開端子蓋。</li> <li>完成測量輸入連接。</li> </ol> | <ol style="list-style-type: none"> <li>將 EM530 RG 安裝於 DIN 導軌上。</li> <li>打開端子蓋。</li> <li>完成測量輸入連接。</li> </ol> |
|---|--|--|
- 
- |   |  |  |
|---|--|--|
| <p><b>Un (L-N)</b> 120 ... 240 V</p> <p><b>Un (L-L)</b> 208...415 V</p> <p><b>Voltage tolerance</b> -20 +15%</p> <p><b>Frequency</b> 50...60 Hz</p> <p><b>Current range</b> 600 A 1200 A 2400 A</p> <p><b>I<sub>max</sub></b> 720 A 1440 A 2880 A</p> | <p><b>Un (L-N)</b> 120 ...240 V</p> <p><b>Un (L-L)</b> 208...415 V</p> <p><b>电压容差</b> -20, +15%</p> <p><b>频率</b> 50...60 Hz</p> <p><b>当前范围</b> 600 A 1200 A 2400 A</p> <p><b>I<sub>max</sub></b> 720 A 1440 A 2880 A</p> | <p><b>Un (L-N)</b> 120 ...240 V</p> <p><b>Un (L-L)</b> 208...415 V</p> <p><b>電壓公差</b> -20, +15%</p> <p><b>頻率</b> 50...60 Hz</p> <p><b>目前範圍</b> 600 A 1200 A 2400 A</p> <p><b>I<sub>max</sub></b> 720 A 1440 A 2880 A</p> |
|---|--|--|
- 
- |  |   |   |
|--|---|---|
| <ol style="list-style-type: none"> <li>Close and seal the terminal caps.</li> <li>Connect the inputs and communication interfaces:<br/>A: Digital input<br/>B: Digital output<br/>C: M-Bus port<br/>D: RS485 port</li> <li>Turn on power.</li> <li>Configure EM530 RG</li> </ol> | <ol style="list-style-type: none"> <li>關閉並密封端子蓋。</li> <li>連接輸入端與通訊介面:<br/>A: 數位輸入<br/>B: 數位輸出<br/>C: M-Bus 埠<br/>D: RS485 埠</li> <li>開啟電源。</li> <li>配置 EM530 RG。</li> </ol> | <ol style="list-style-type: none"> <li>關閉並密封端子蓋。</li> <li>連接輸入端與通訊介面:<br/>A: 數位輸入<br/>B: 數位輸出<br/>C: M-Bus 埠<br/>D: RS485 埠</li> <li>開啟電源。</li> <li>設定 EM530 RG。</li> </ol> |
|--|---|---|

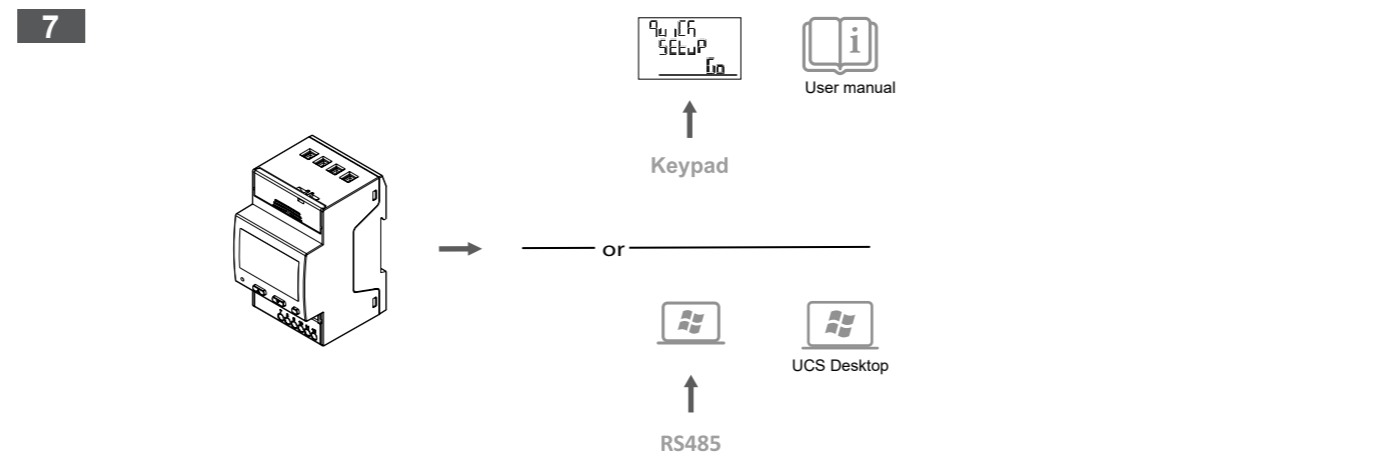
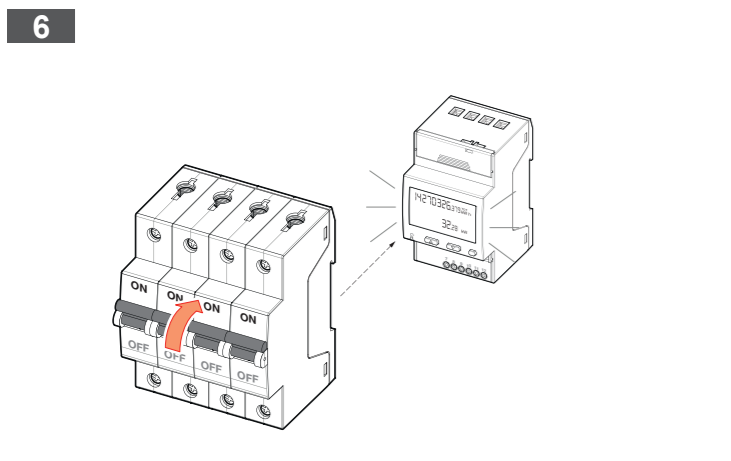
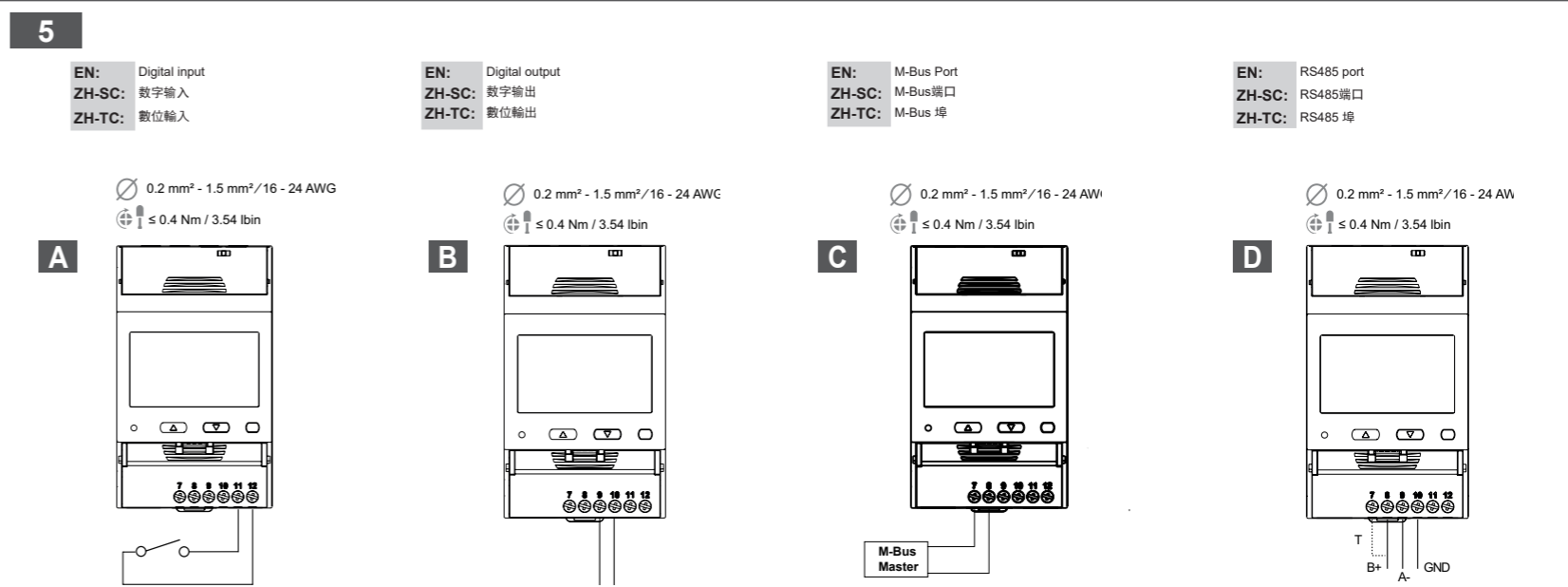
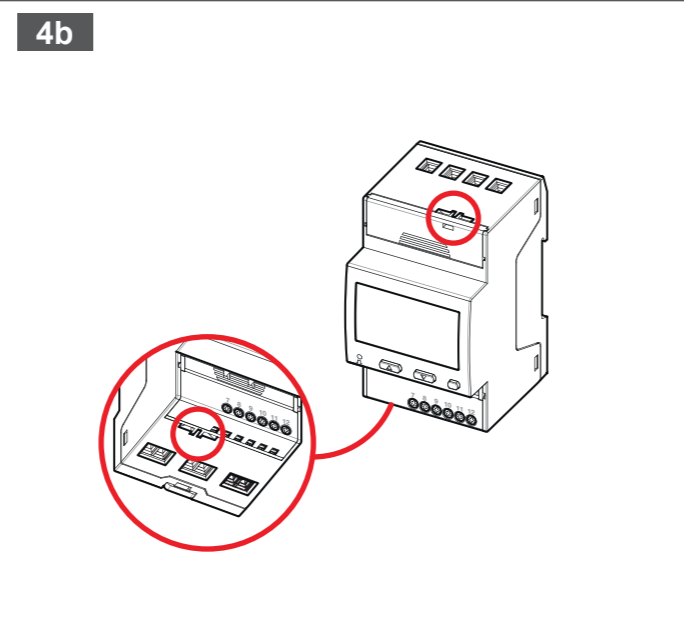
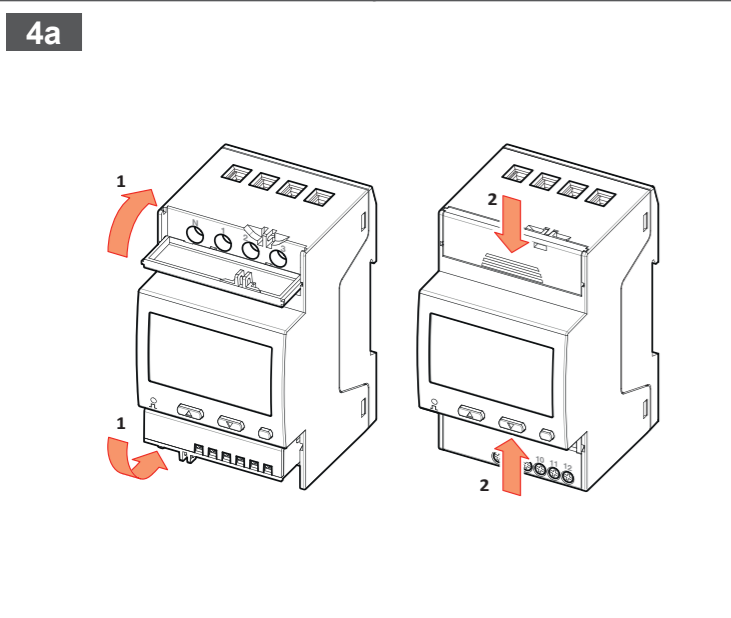
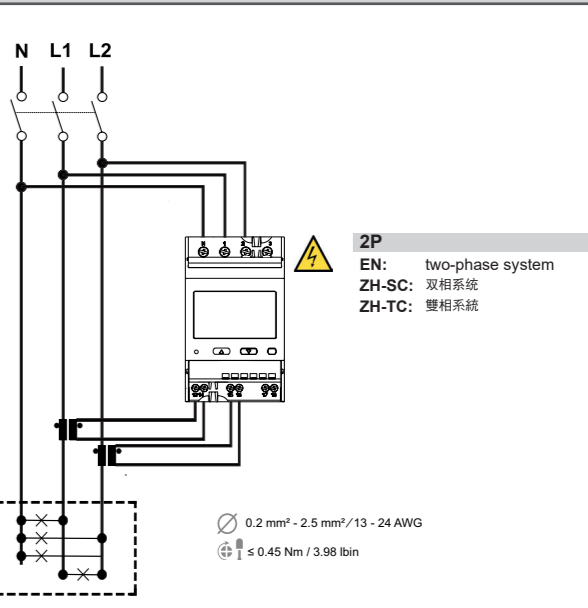
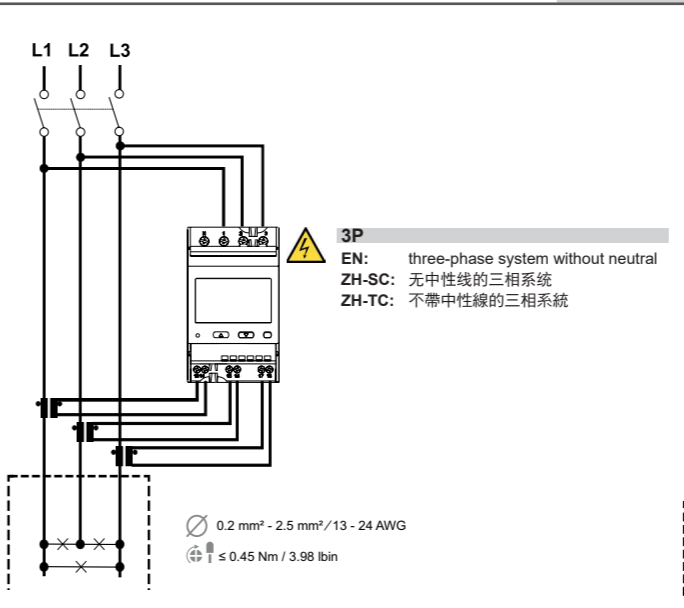
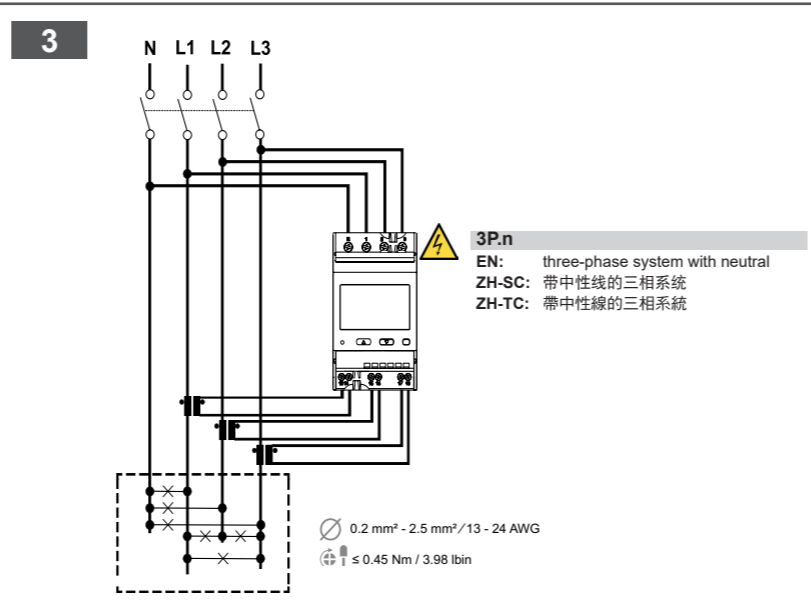
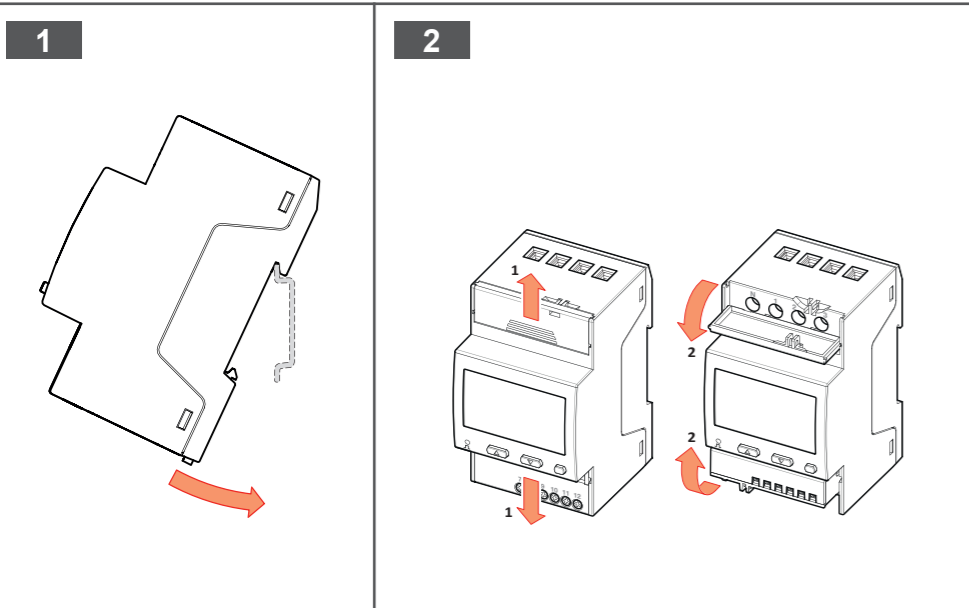
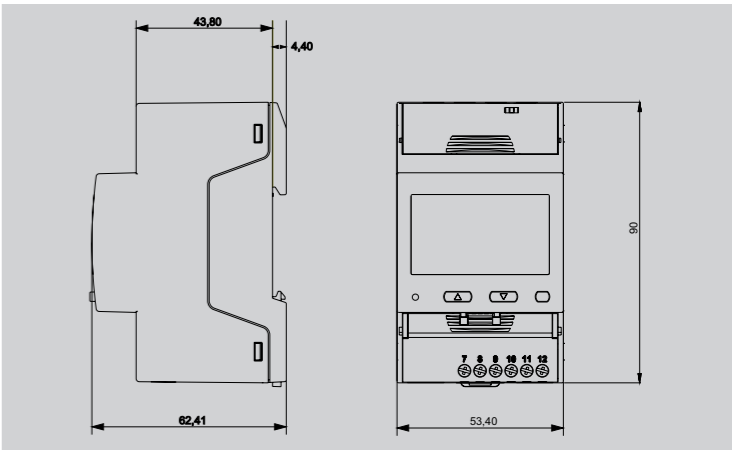

**User manual** [https://www.gavazziautomation.com/images/PIM/MANUALS/ENG/EM500\\_IM\\_USE.pdf](https://www.gavazziautomation.com/images/PIM/MANUALS/ENG/EM500_IM_USE.pdf)

**UCS Desktop** <https://www.gavazziautomation.com/images/PIM/OTHERSTUFF/ucs.zip>

**CARLO GAVAZZI**

CARLO GAVAZZI Controls SpA  
via Safforze, 8 32100 Belluno (BL) Italy  
www.gavazziautomation.com  
info@gavazzi-automation.com  
info: +39 0437 355811 / fax: +39 0437 355880

www.gavazziautomation.com

19/02/26| 8022427| COPYRIGHT ©2026